

Value Stream Mapping of a *Complete* Product

Shahrukh A. Irani and Jin Zhou
Department of Industrial, Welding and Systems Engineering
The Ohio State University
Columbus, OH 43210

Introduction

Lean Thinking, a concept that is based on the Toyota Production System, extends continuous improvement efforts to reduce the costs of serving customer/s beyond the physical boundaries of a manufacturing facility, by including the suppliers, distributors and production system that support the manufacturing function [Womack and Jones, 1996]. These improvements and cost reductions are achieved by eliminating the *muda* (wastes) associated with all activities performed to deliver an order to a customer. Wastes are defined as “all activities that consume resources (add costs to the product) but contribute zero value to the customer.” According to Womack and Jones, there are five steps for implementing *Lean Thinking* in an enterprise: 1) Define Value from the perspective of the Customer, 2) Identify the Value Streams, 3) Achieve Flow, 4) Schedule production using Pull, and 5) Seek Perfection through Continuous Improvement. Womack and Jones define a Value Stream as “the set of all the specific actions required to bring a specific product through the three critical management tasks of any business: ...problem solving, ...information management, ...physical transformation”. Alternatively, Rother and Shook define a Value Stream as “all the actions (both value-added and non-value-added) currently required to bring a product through the main flows essential to every product” [Rother and Shook, 1999, p. 3].

Overview of Value Stream Mapping

Value Stream Mapping (VSM) is the process of mapping the material and information flows required to coordinate the activities performed by manufacturers, suppliers and distributors to deliver products to customers. Unlike the traditional process mapping tools used by IE's, VSM is a mapping tool that maps not only material flows but also information flows that signal and control the material flows. This enhanced visual representation facilitates the identification of the value-adding steps in a Value Stream and elimination of the non-value adding steps, or wastes (*muda*). Using VSM, many OEM's and their top-tier suppliers have changed their existing facility layouts, as well as existing systems for material handling, inventory control, purchasing and scheduling, to reduce the total throughput times of orders and current levels of work-in-process (WIP) inventories.

A typical VSM project involves the development of maps: (1) a Current State Map and (2) one or more Future State Maps that represent progressive improvements in the Current State Map. In the Current State Map, one would normally start by mapping a product family that accounts for a significant proportion of the total annual production volume and sales earnings (or even profit margin) of the company. Usually, the material

flow is mapped on an 11 X 17 sheet of paper using appropriate icons. The (material) flow of the product is traced back from the final operation in its routing to the storage location for raw material. Relevant data for each operation, such as the current schedule (push, pull, and order dispatching rules in effect at any process ex. FIFO) and the amount of inventory in various queues, is recorded on the map. The information flows are also incorporated to provide demand information, which is an essential parameter for determining the “pacemaker” process in the manufacturing system for which the Current State Map is being developed. After both material and information flows have been mapped, a time-line is displayed at the bottom of the map showing the processing time for each operation and the transfer delays between operations. The time-line is used to identify the value-adding steps, as well as wastes, in the current system. A comparison of the processing times and the takt time (calculated as Available Capacity/Customer Demand) serves as a preliminary measure of the value and wastes in the current system. This takt time is mostly used as an ideal production rate for each operation to achieve. Ideally, the cycle time for each operation in a Value Stream should be less than or equal to the takt time.

Based on the Current State Map, a Future State Map is generated for improving the value-adding steps and eliminating the non-value adding steps (waste) in the current system. Based on the concepts of Lean Thinking, Rother & Shook provide seven guidelines to follow when generating the Future State Map for an improved manufacturing system (Rother and Shook, 1999, p. 44-54):

1. Produce to takt time
2. Develop continuous flow
3. Use supermarkets to control production where continuous flow does not extend upstream
4. Schedule based on the pacemaker operation
5. Produce different products at a uniform rate (Level the production mix)
6. Level the production load on the pacemaker process (Level the production volume)
7. Develop the capability to make “every part every (EPE) <time period>”

Pros of Value Stream Mapping: An Industrial Engineering Viewpoint

- Relates the manufacturing process to supply chains, distribution channels and information flows.
- Integrates material and information flows.
- Links Production Control and Scheduling (PCS) functions such as Production Planning and Demand Forecasting to Production Scheduling and Shopfloor Control using operating parameters for the manufacturing system ex. takt time which determines the production rate at which each processing stage in the manufacturing system should operate.

- Helps to unify several IE techniques for material flow analysis, such as Production Flow Analysis (PFA), Business Process Reengineering (BPR), and Process Analysis and Improvement (PA&I) that, to date, have been taught and implemented *in isolation*.
- Provides important descriptive information for the *Operation* and *Storage* icons in the standard Flow Process Charts used by IE's.
- Forms the basis for implementation of Lean Manufacturing by designing a manufacturing system based on the complete dock-to-dock flow time for a product family.
- Provides a company with a “blueprint” for strategic planning to deploy the principles of Lean Thinking to facilitate their transformation into a Lean Enterprise.

Cons of Value Stream Mapping: An Industrial Engineering Viewpoint

- Fails to map multiple products that do not have identical manufacturing routings or assembly process flows.
- Fails to relate *Transportation* and *Queuing* delays, and changes in transfer batch sizes due to poor plant layout and/or material handling, to operating parameters (ex. machine cycle times) and measures of performance (ex. takt time)¹ of the manufacturing system.
- Lacks an economic measure for “value”, such as profit, throughput, operating costs, inventory expenses, etc. unlike the Flow Process Charting technique used by IE's.
- Lacks the spatial structure of the facility layout, and how that impacts inter-operation material handling delays, the sequence in which batches enter the queue formed at each processing step in the manufacturing routing/s, container sizes, trip frequencies between operations, etc.
- Tends to bias a factory designer to consider *only* those strategies², such as continuous flow, assembly line layouts, kanban-based Pull scheduling, etc., that are suitable mainly for high-volume low-variety (HVLV) manufacturing facilities.
- Fails to consider the allocations and utilization of an important resource – factory floor space – for WIP storage, production support, material handling aisles, etc.

¹ Reasons for this could be (a) the impact of a poor facility layout on order throughput, product quality and operating costs is assumed to be trivial by the developers of VSM or (b) superimposing all the information contained in a VSM onto a CAD drawing of the facility layout reduces the readability of the map.

² These are design and operational strategies that are suited mainly for low-variety high-volume (LVHV) facilities, such as automotive OEM's and their Tier 1 or Tier 2 suppliers, and **not** the sub-tier suppliers and other Make-To-Order manufacturers who operate high-variety low-volume (HVLV) facilities.

- Fails to show the impact that in-efficient material flows in the facility ex. backtracking, criss-cross flows, non-sequential flows, large inter-operation travel distances, etc. have on WIP, order throughput and operating expenses.
- Fails to handle the complete BOM (Bill Of Materials) of a product since that usually results in a branched and multi-level Value Stream.
- Fails to factor queuing delays, sequencing rules for multiple orders, capacity constraints, etc. in any map³.
- Lacks the capability, due to the manual mapping method, for *rapid* development and evaluation of multiple “what if” analyses required to prioritize different alternatives for improving a Current State Map when time and/or budget constraints exist.

Value Network Mapping (VNM)

A fundamental limitation of Value Stream Mapping (VSM) is that it is a *manual* method for mapping and analysis of the flows of products, materials, people, information, etc. in manufacturing facilities [Rother and Shook, 1999, p. 19]. The limitations of this “pencil and paper” method become especially obvious when it is deployed in a typical high-variety low-volume (HVLV) facility that makes a complex fabricated assembly or a large mix of components with different manufacturing routings. The task of generating a Current State Map by hand, for even a small sample of 15-20 parts using 10 or more different workcenters, is identical to the mapping of multi-product flows to design a facility layout [Apple, 1977] because it is a frustrating, iterative and time-consuming effort! To address this problem, the developers of VSM simply state that “... (when) many value streams have multiple flows that merge... draw such flows over one another ... but do not try to draw every branch if there are too many. Choose the key components first, and get the others later if you need to ... just draw the flow for one or two main raw materials” [Rother and Shook, 1999, p. 24]. Unfortunately, their manual approach to *identify and aggregate* identical or similar value streams with common process steps often results in numerous revisions of the locations of the process boxes in the Current State Map. In addition, incorrect location of the various process boxes in the Current State Map could unnecessarily make the material flows in the map appear as a chaotic spaghetti diagram⁴, such as shown in Figure 9. Hence, in order to deploy VSM in any HVLV manufacturing facility, it is important to *first* draw a Current State Map that is clutter-free with minimum criss-crossing of the material flow paths of multiple product/s sharing common workcenters.

In this paper, we propose a computer-aided method for HVLV manufacturing facilities – Value Network Mapping (VNM) – that is an effective alternative to the manual method of Value Stream Mapping. Given the network of interacting value streams corresponding

³ This could be easily and effectively done if queuing network analysis, simulation or a Finite Capacity Scheduling (FCS) software were used to develop and model the performance of the manufacturing system represented in a Current State Map.

⁴ For further details, please refer to [Muther 1955, Chapter 15, Pages 193-209].

to an assembled product or a large sample of different parts, VNM can (a) retain the parent-child relationships in the assembly and (b) aggregate the value streams of components and sub-assemblies with identical, or similar, manufacturing routings. In essence, when the process steps contained in different VSMS are not absolutely identical, VNM helps to aggregate similar value streams "... in such a way that several products can pass through each step with some slight detours if required, as in a manufacturing cell ..." [Womack and Withers, www.lean.org].

An Illustrative Example of Value Network Mapping

In a typical Make-To-Order manufacturing facility, a large number of parts from "feeder" shops (or departments), such as machining, stamping, welding, injection molding, casting, etc. flow into the assembly department in the facility [Costanza, 1996, Chapter 3]. This situation is exemplified by the Operations Process Chart (OPC)⁵ in Figure 1 for a simple gate valve assembly described in the literature [Apple, 1977]. When creating a map for this complete product, the material flow portion of the VNM *must* retain (a) the assembly precedence relationships between the different in-house and purchased components and subassemblies *and* (b) the material flow routes of the individual components that are manufactured and assembled into the final product. This is because a primary end-result is the design of a focused factory layout for the gate valve assembly that exhibits "lean" (waste-free) flow of materials at all stages of realization of the final product. In order to make materials flow, the factory layout should (a) minimize the total travel distance for all (seven) components until they reach the assembly line, (b) minimize the duplication/splitting of identical processes (or operation types) at multiple (non-adjacent) locations in the layout, (c) identify the locations for Point-Of-Use storage of kits of parts [Costanza, 1996, Chapter 5] and (d) identify potential bottlenecks in the network where capacity constraints could result in throughput delays [Goldratt and Fox, 1986]. Using suitable algorithms in the PFAST package [Irani et al, 2000], the spreadsheet in Table 1 representing the Operations Process Chart (OPC) for the gate valve assembly was manipulated and rearranged, as shown in Table 2. This reordering was done to aggregate identical routings or to place side-by-side routings with common process steps, as shown in Table 3. Based on Table 3, the original OPC in Figure 1 was redrawn, as shown in Figure 2.

Utility of a Value Network Map

The locations for the different process boxes in Figure 2 become the basis for drawing the Value Network Map for the gate valve assembly on a sheet of paper. It minimizes criss-cross flows among process boxes that could have been incorrectly located in a hand-drawn Current State Map for the same product. Thereby, the computer-aided method of Value Network Mapping (VNM) helps to reduce the chaos (and frustration) of implementing Value Stream Mapping in complex manufacturing facilities.

Based on the initial VNM shown in Figure 2, it may be required to determine if certain workcenters must be duplicated at several locations to eliminate criss-cross flows in the

⁵ For further details, please refer to [Muther, 1955, Page 176, Figure 14-1].

focused factory. Figure 3 and Figure 4 suggest alternative scenarios for equipment duplication that could be evaluated using criteria such as capital investment costs, WIP costs and reductions in operational wastes, especially queuing and material handling delays.

A Real-World Example of Value Network Mapping

This section is based on a project to design a modular Point-Of-Use layout for a fabrication assembly facility producing industrial scales [Zhou and Irani, 2000]. Figure 6 shows the original OPC that was generated from the Indented Bill Of Routings for the Product # 2185002065-A (See Appendix). This visual representation of the product that is provided by the OPC clearly shows three subassemblies TB201990, TC201989-1, TC202034-1, and the company-specified storage locations X, Y, Z for different parts. Figure 7 shows the original OPC rearranged to show families of parts with identical or similar manufacturing routings whose value streams could be merged or aggregated into a single value network. Figure 8 shows the current layout of the assembly facility. Figure 9 shows the spaghetti diagram corresponding to the flows of all components and subassemblies, including the final assembly, in the existing facility layout. Several important observations can be made from this spaghetti diagram:

1. The chaotic flows in this spaghetti diagram would be ignored had one used Value Stream Mapping and generated a Current State Map for the material flow network.
2. The significant occurrence of backtracking and cross flows in the facility, such as the flows 763SHR16→761PUNCH, 761PUNCH→763PRBRK, 761ASY→811ASM, 770WHLBR→ 771HCFIN, etc. would be ignored had one used Value Stream Mapping and generated a Current State Map for the material flow network.
3. Why is it necessary to have all three of the current kitting locations X, Y and Z shown in Figure 8?

Figure 10 is an extension of Figure 7 and shows similar parts from the three major subassemblies that could be produced in a single cell. The potential for aggregation of identical and/or similar manufacturing routings into one or more sub-networks of value streams in the overall Value Network Map for the product is illustrated in Figure 11. This is reasonable since the routings of parts that constitute subassembly TB201990 are completely contained in the routings of parts that constitute subassembly TC201989-1. Thus, a single “feeder” cell could be designed to produce both these subassemblies. Figure 11 also shows that there is only one common work center - 761PUNCH – common to the value streams for the two subassemblies, TC201989-1 and TC202034-1. Therefore, it is further possible to implement two “feeder” cells, one to produce TB201990 and TC201989-1 and the other to produce TC202034-1. Subsequently, these cells could feed parts into a common supermarket located at the common Work Center 761PUNCH⁶. Figure 12, which is the initial drawing of the Value Network Map for the complete product, easily suggests which pairs of work centers should have been located adjacent to each other to achieve waste-free material flows in the focused factory. For

⁶ Detailed analysis was not done to determine if this workcenter could serve as the Drum in a Drum-Buffer-Rope scheduling system [Goldratt and Fox, 1986] for the focused factory.

example, the forward by-pass flows such as 761DBURR→761HSTUD suggest a U-shaped flowline layout for the string of machines 761DBURR→761FORM→761TWELD→761POLSH→ 761HSTUD/761PEM. Using the Value Network Map in Figure 12, the Point-Of-Use focused factory layout for the facility shown in Figure 13 could easily be designed to achieve waste-free material flows in a Point-Of-Use focused factory layout [Costanza, 1996, Chapter 3]. In fact, the two spaghetti diagrams in Figure 9 and Figure 13 constitute the material flow networks in the as-is Current State Map and the to-be Future State Map for the manufacturing facility.

Limitations and Future Enhancements in Value Network Mapping

Since a typical Value Network Map will involve large numbers of value streams and process boxes, a clutter-free drawing of the complete material flow network is a must. Figures 5(a)-(c) present a preliminary idea of a Bubble Diagram-like grid [Muther, 1955, p. 196, Figure 15-4] on which the process boxes could be entered in order to make adjacent strongly-connected pairs of workcenters in the material flow network. Further, the size of paper on which the map is drawn could constrain the number of process boxes, and therefore number of value streams, that could be included in a *single* map. In which case, for complex products and large samples of components, connections among multiple maps will need to be established and maintained.

The icons used for Value Stream Mapping are relevant mainly for assembly line-like repetitive flow systems for low-variety high-volume (LVHV) manufacturing facilities. Jobshops and Make-To-Order manufacturing systems have considerably more complex material flow networks, and produce orders to customer-specified due dates using finite capacity scheduling methods. Therefore, a new set of icons is being developed for VNM that can be obtained for evaluation from the authors on request.

How does one show all the data for a large number of components at each workcenter? And, if one were to incorporate details relating to production control, operations scheduling and shopfloor control on the same map that contains the material flow network, then the resulting map would easily become unreadable. Hence, it is desired to develop a separate map showing the information flows involved in the manufacturing system being studied.

Lastly, a typical Make-To-Order assembly facility produces a wide range of products that use different combinations of parts and subassemblies, whose routings will therefore feature different sets of workcenters located in the same facility. Hence, the proposed method must be enhanced to represent, possibly aggregate, multiple OPC's for different products being produced in the same facility.

Conclusion

By automatically aggregating Value Streams with identical or similar material flow routes, the Value Network Mapping (VNM) method offers significant advantages over the manual method of Value Stream Mapping (VSM). VSM is inadequate for a typical

HVLV manufacturing facility, where a large number of value streams involving a large number of value streams (and workcenters contained in those streams), is involved. In contrast, VNM ensures that, when the individual Value Streams are drawn by connecting the appropriate process boxes as per their manufacturing routing, a “spaghetti diagram” results that has very few, if any, backtracking and criss-cross flows.

References

- Apple, J. M. (1977). *Plant Layout and Material Handling*. New York, NY: John Wiley.
- Costanza, J. (1996). *The Quantum Leap in Speed-To-Market*. Denver, CO: John Costanza Institute of Technology, Inc.
- Goldratt, E.M. & Fox, R.F. (1986). *The Race*. Croton-on-Hudson, NY: North River Press.
- Irani, S.A., Zhang, H., Zhou, J., Huang, H., Udai, T.K. & Subramanian, S. (2000). Production Flow Analysis and Simplification Toolkit (PFAST). *International Journal of Production Research*, 38(8), 1855-1874.
- Moore, R. & Scheinkopf, L. (1998). *Theory of Constraints and Lean Manufacturing: Friends or Foes?* Chesapeake Consulting, Inc: www.chesapeake.com.
- Muther, R.M. (1955). *Practical Plant Layout*. New York, NY: McGraw-Hill.
- Rother, M. & Shook, J. (1999, June). *Learning to See*. Version 1.2. Brookline, MA: Lean Enterprise Institute.
- Zhou, J. & Irani, S.A. (2000, June 27-30). Design of modular layouts for fabrication-based assembly facilities. *Proceedings of the Third World Congress on Intelligent Manufacturing Processes & Systems*, Massachusetts Institute of Technology, Cambridge, MA, and the International Institution for Production Engineering Research (CIRP), 62-69.
- Womack, J. P. & Jones, D. T. (1996). *Lean Thinking: Banish Waste and Create Wealth in your Corporation*. New York, NY: Simon & Schuster.

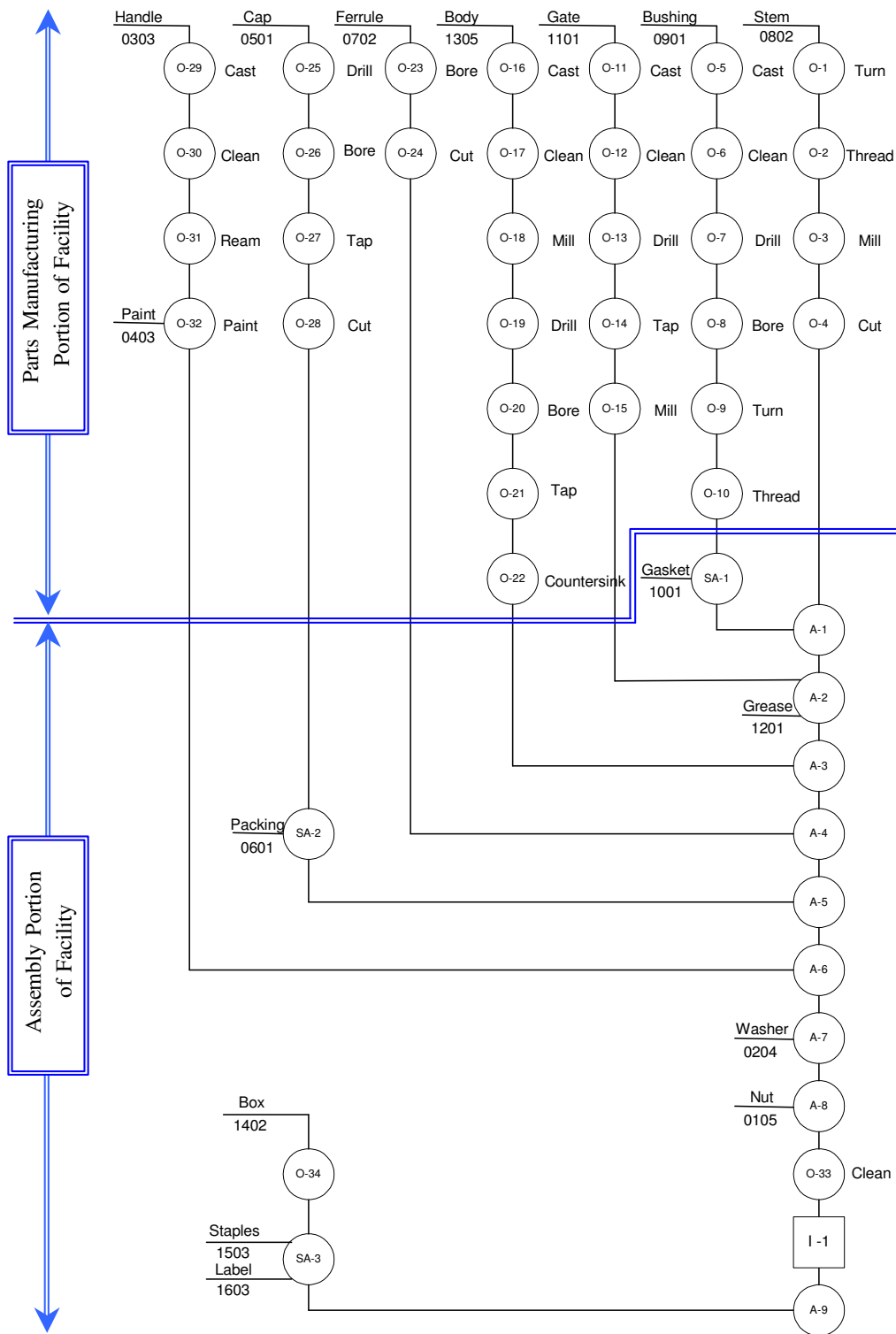

Figure 1 Operations Process Chart for the Gate Valve Assembly

Table 1 Initial Spreadsheet Representation of the Value Network Map

Parts						
Handle	Cap	Ferrule	Body	Gate	Bushing	Stem
Cast	Drill	Bore	Cast	Cast	Cast	Turn
Clean	Bore	Cut	Clean	Clean	Clean	Thread
Ream	Tap	A-4	Mill	Drill	Drill	Mill
Paint	Cut	A-5	Drill	Tap	Bore	Cut
A-6	SA-2	A-6	Bore	Mill	Turn	A-1
	A-5		Tap	A-2	Thread	A-2
	A-6		Countersink	A-3	SA-1	A-3
			A-3	A-4	A-1	A-4
			A-4	A-5	A-2	A-5
			A-5	A-6	A-3	A-6
			A-6		A-4	
					A-5	
					A-6	

Table 2 Final Spreadsheet Representation of the Value Network Map

Parts						
Handle	Body	Gate	Bushing	Stem	Ferrule	Cap
Cast	Cast	Cast	Cast			
Clean	Clean	Clean	Clean			
Ream	Mill					
Paint	Drill	Drill	Drill			
	Bore		Bore			
	Tap	Tap	Turn	Turn		Drill
	Countersink	Mill	Thread	Thread	Bore	Bore
			SA-1	Mill		Tap
				Cut	Cut	Cut
			A-1	A-1		SA-2
		A-2	A-2	A-2		
	A-3	A-3	A-3	A-3		
	A-4	A-4	A-4	A-4	A-4	
	A-5	A-5	A-5	A-5	A-5	A-5
A-6	A-6	A-6	A-6	A-6	A-6	A-6

Table 3 Aggregation of Common Process Steps in Multiple Value Streams

Parts						
Handle	Body	Gate	Bushing	Stem	Ferrule	Cap
Cast						
Clean						
Ream	Mill					
Paint	Drill					
	Bore		Bore			
	Tap		Turn			Drill
	Countersink	Mill	Thread		Bore	
			SA-1	Mill		Tap
			Cut			
			A-1			SA-2
			A-2			
			A-3			
			A-4			
			A-5			
			A-6			

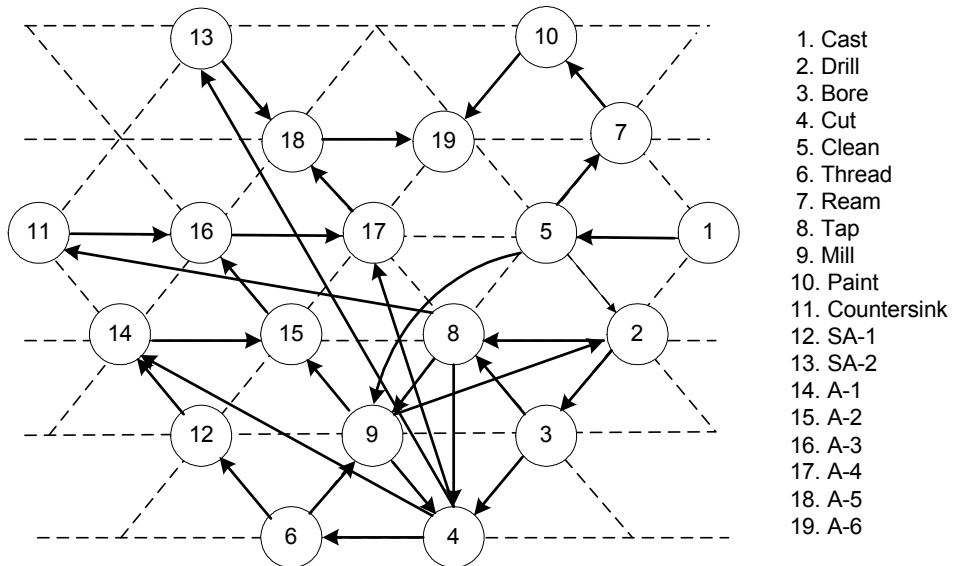

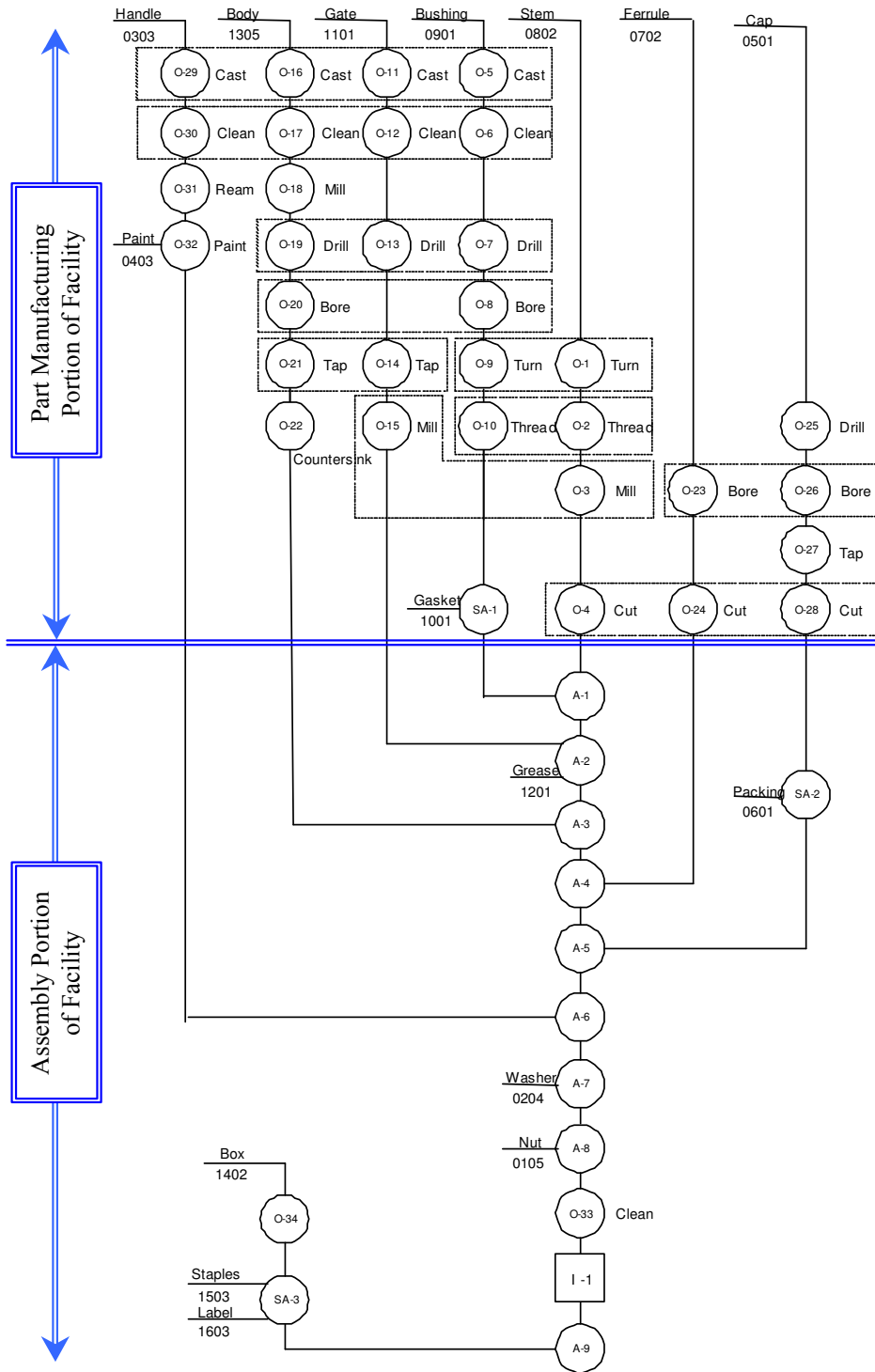

Figure 2 Rearranged Operations Process Chart for the Gate Valve Assembly

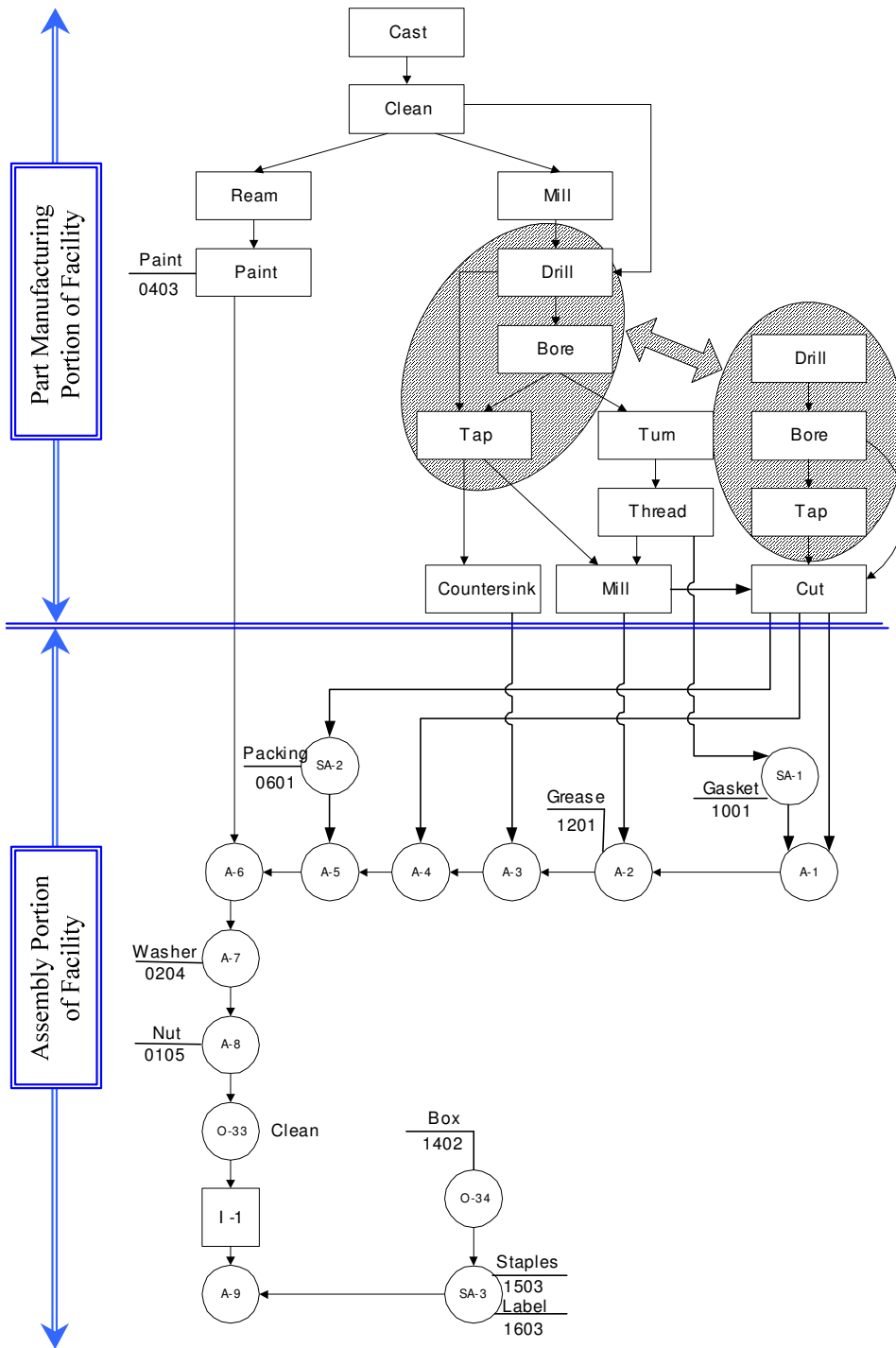

Figure 3 Value Network Map for the Gate Valve Assembly: Alternative #1

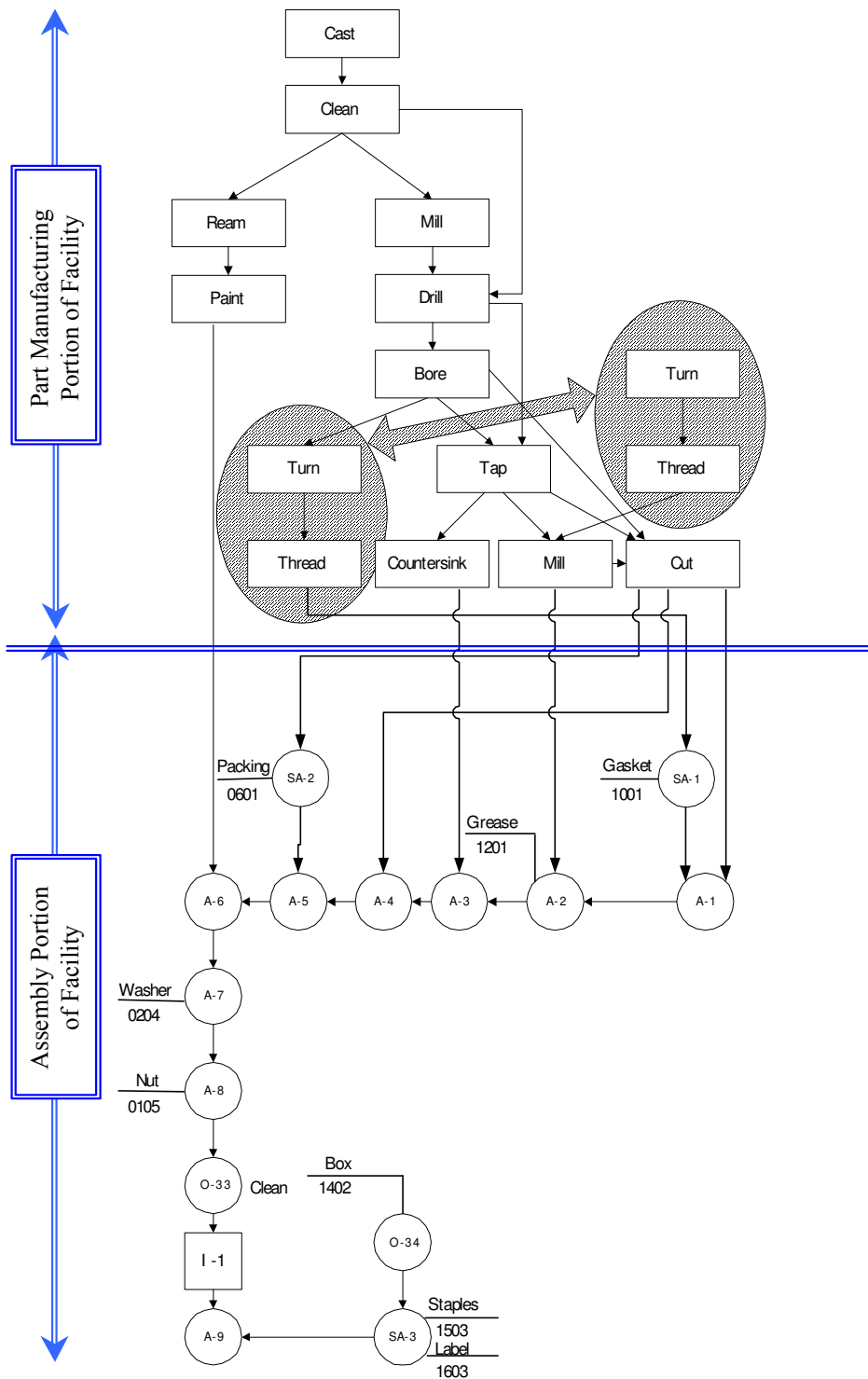

Figure 4 Value Network Map for the Gate Valve Assembly: Alternative #2

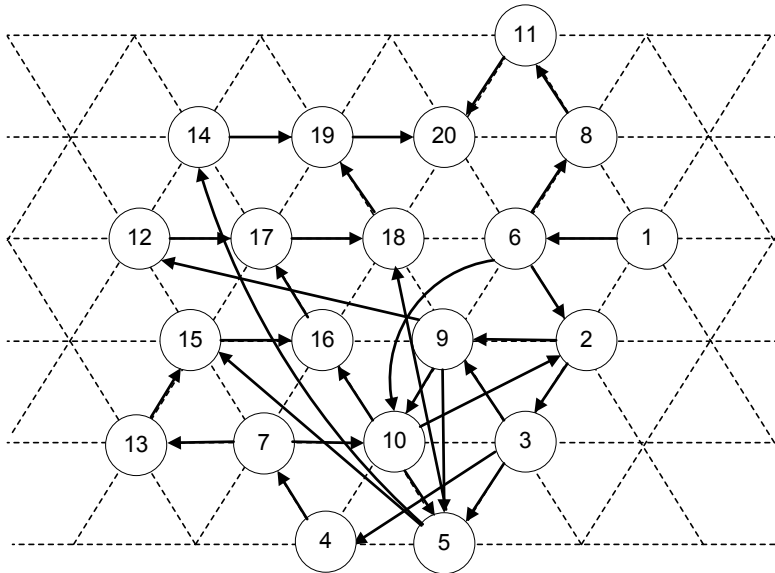

Figure 5(a) Bubble Diagram for Figure 3

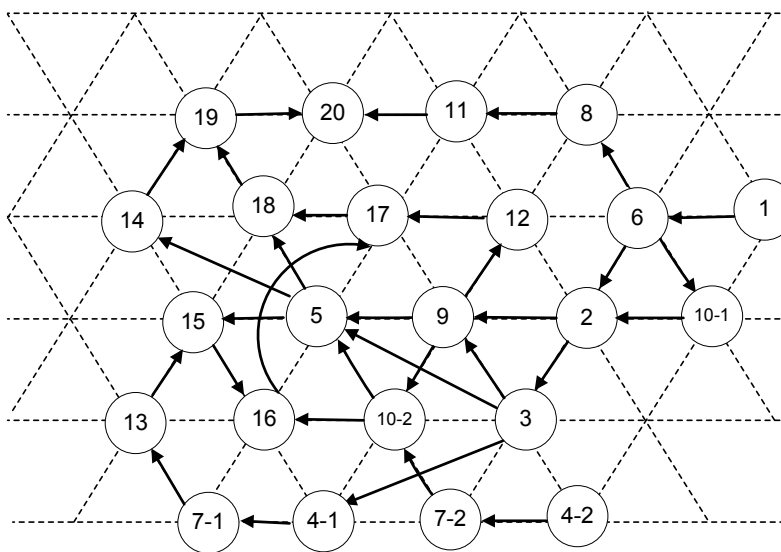

Figure 5(b) Bubble Diagram for Figure 4

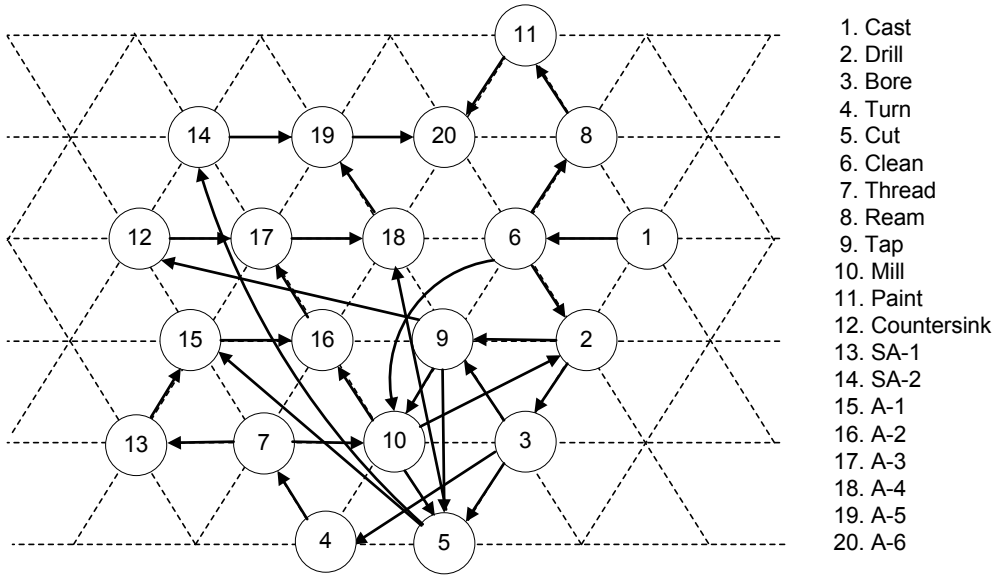

Figure 5(c) Bubble Diagram for Figure 1

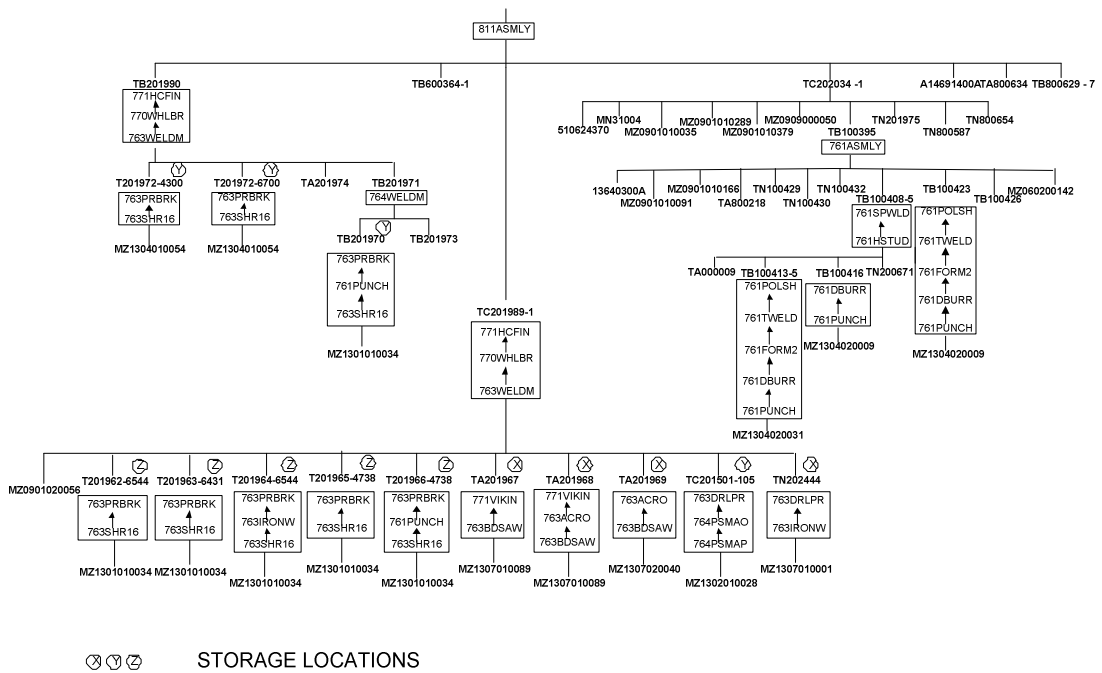
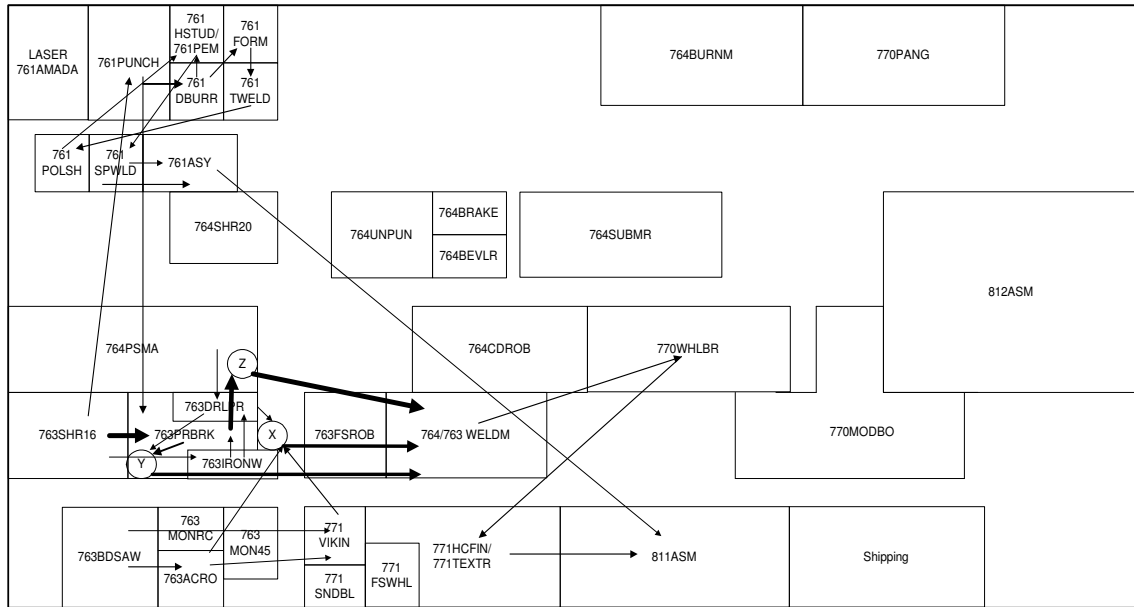

Figure 6 Operations Process Chart for Product #2158002065 - A



(X) (Y) (Z) STORAGE LOCATIONS

Figure 9 Spaghetti Diagram for Product # 2158002065-A

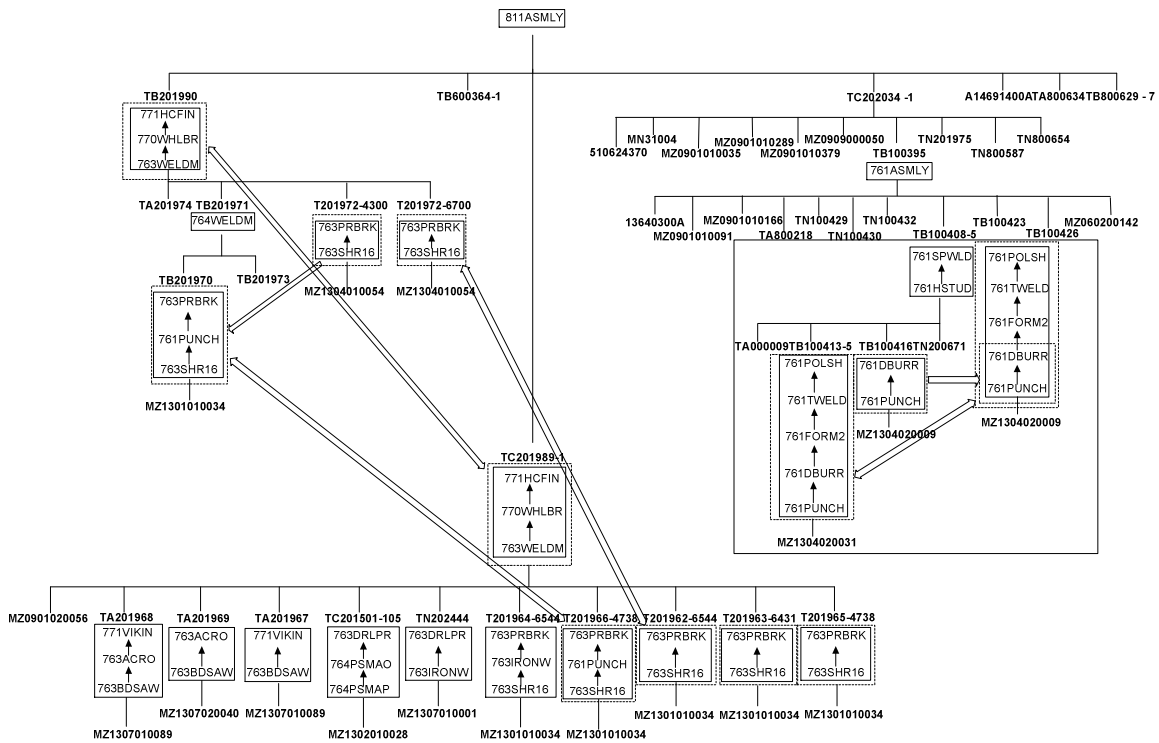

Figure 10 Comparison of Value Streams across Subassemblies

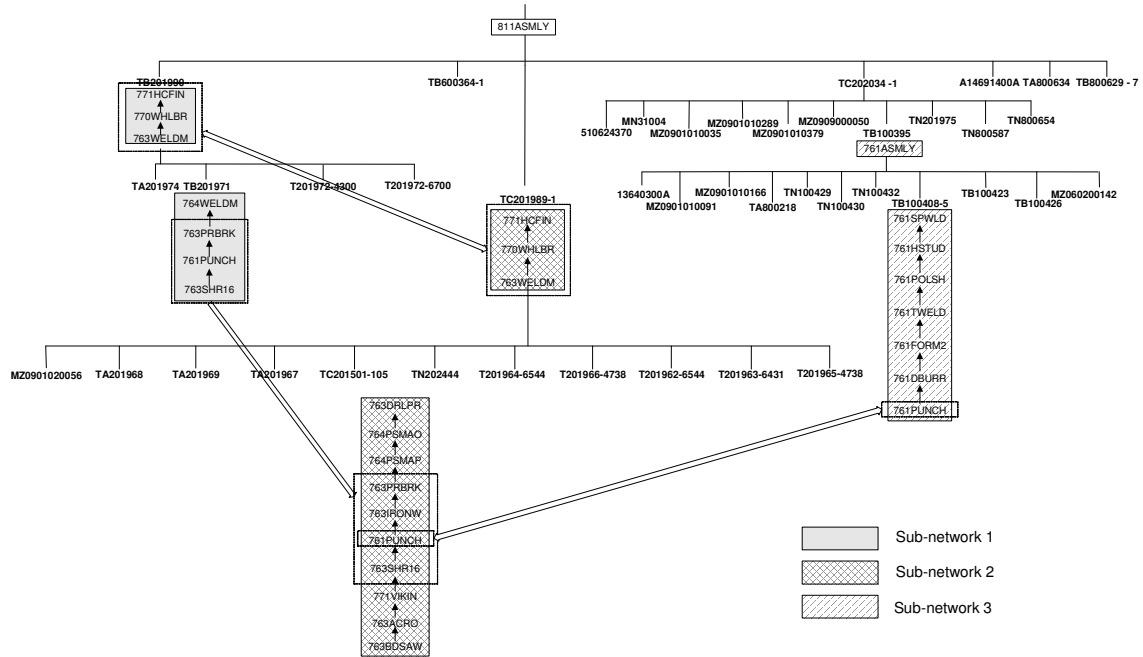

Figure 11 Aggregation of Multiple Value Streams in Product # 2158002065 – A

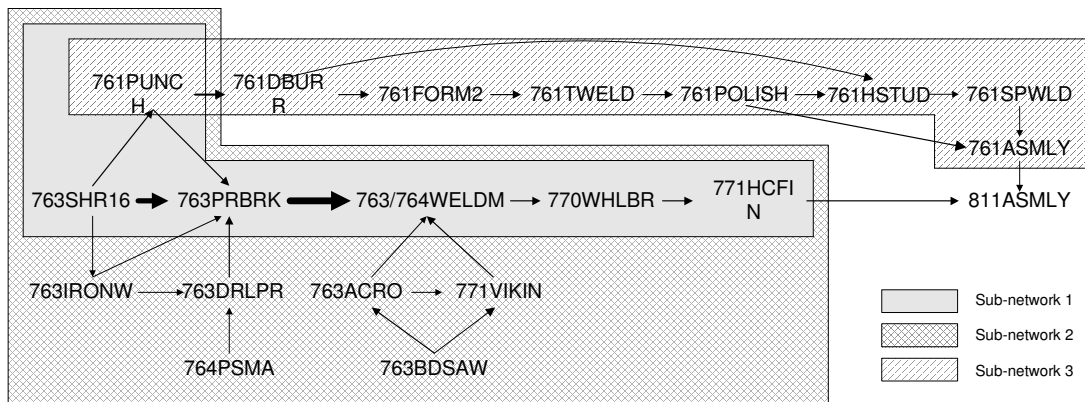

Figure 12 Value Network Map for Product # 2158002065 – A

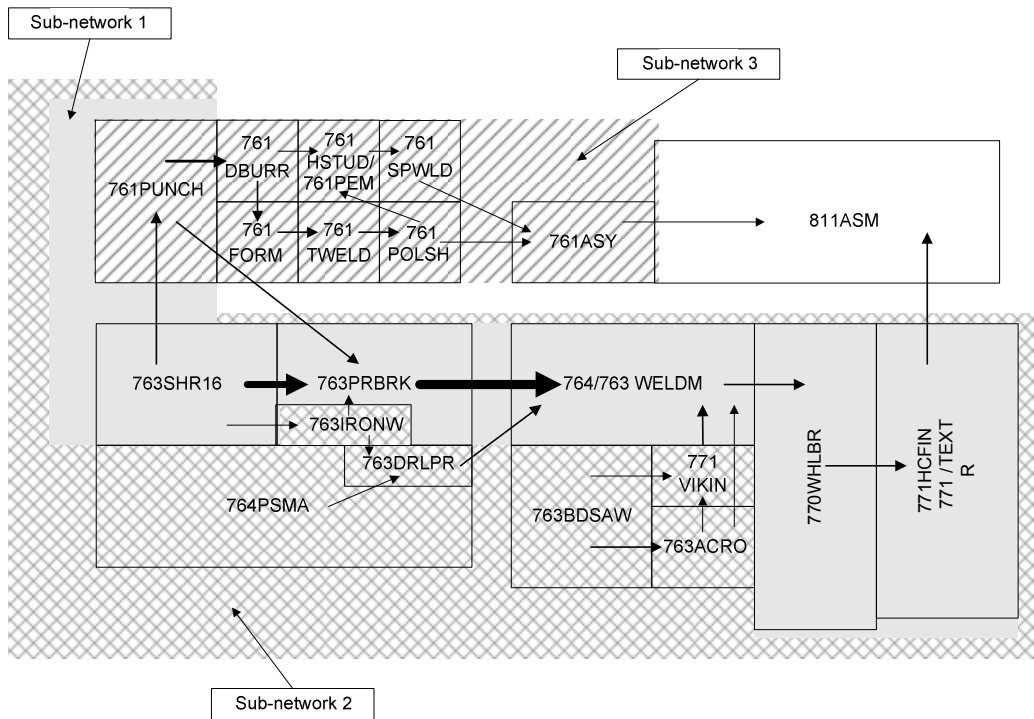

Figure 13 Point-Of-Use (POU) Facility Layout based on Value Network Map

APPENDIX

Indented Bill Of Routings for Product # 2185002065-A

15:44:14
FUNCTION: MBIL

MULTI-LEVEL BILL INQUIRY

PAGE: 1
07/21/1999

PARENT: 2158002065-A
RV: UM:EA
PLNR: 3KB

DESC: 2158, ●, 20K, 5X7, 4KD
RUN LT: 1 FIXED LT: 3
PLN POL: N DRWG: TC202034

LEVEL	PT	USE	SEQN	COMPONENT	C PARTIAL	T DESCRIPTION	QTY	UM	Q	M	LT	SCR
1...5...10									T	B	OFF	PCT
1	0		010	WC[R]811ASMLY	R	ASSEMBLY, F/S	1.5	HR	I	M	0	0.0
1	0		900	TB201990	N	2158, FRAME, CS,	1	EA	I	M	0	0.0
2	0		010	WC[R]763WELDM	R	WELD, MANUAL WE	.5	HR	I	M	0	0.0
2	0		020	WC[R]770WHLBR	R	SHOTBLAST, WHEE	.1	HR	I	M	0	0.0
2	0		030	WC[R]771HCFIN	R	PAINT, HEAVY-CA	.5	HR	I	M	0	0.0
2	0		900	T201972-4300	P	ANGLE, CS, 7GAX2	2	EA	I	M	0	0.0
3	0		010	WC[R]763SHR16	R	SHEAR 16'	.01	HR	I	M	0	0.0
3	0		020	WC[R]763PRBRK	R	FORM, PRESS BRA	.01	HR	I	M	0	0.0
3	0		900	MZ1304010054	N	SHEET, 7GAX48.7	11.96	LB	I	B	0	0.0
2	0		900	T201972-6700	P	ANGLE, CS, 7GAX2	2	EA	I	M	0	0.0
3	0		010	WC[R]763SHR16	R	SHEAR 16'	.01	HR	I	M	0	0.0
3	0		020	WC[R]763PRBRK	R	FORM, PRESS BRA	.01	HR	I	M	0	0.0
3	0		900	MZ1304010054	N	SHEET, 7GAX48.7	18.63	LB	I	B	0	0.0
2	0		900	TA201974	N	2158, BEARING, L	4	EA	I	B	0	0.0
2	0		900	TB201971	P	2158, FRAME COR	4	EA	I	M	0	0.0
3	0		010	WC[R]764WELDM	R	WELD, MANUAL WE	.15	HR	I	M	0	0.0
3	0		900	TB201970	P	2158, FRAME COR	1	EA	I	M	0	0.0
4	0		010	WC[R]763SHR16	R	SHEAR 16'	.01	HR	I	M	0	0.0
4	0		020	WC[R]761PUNCH	R	STRIPPIT	.1	HR	I	M	0	0.0
4	0		030	WC[R]763PRBRK	R	FORM, PRESS BRA	.02	HR	I	M	0	0.0
4	0		900	MZ1301010034	N	PLATE, 1/4X72X1	10.05	LB	I	B	0	0.0
3	0		900	TN201973	N	2158, BUMPER, CS	2	EA	I	B	0	0.0
1	0		900	TB600364-1	N	LC, 745, 10K, 5KD	4	EA	I	B	0	0.0
1	0		900	TC201989-1	N	2158, PLAT, MT, 2	1	EA	I	M	0	0.0
2	0		010	WC[R]763WELDM	R	WELD, MANUAL WE	2.5	HR	I	M	0	0.0
2	0		020	WC[R]770WHLBR	R	SHOTBLAST, WHEE	.1	HR	I	M	0	0.0
2	0		030	WC[R]771HCFIN	R	PAINT, HEAVY-CA	.75	HR	I	M	0	0.0
2	0		900	MZ0901020056	N	NUT, 3/4-10, HEX	4	EA	I	B	0	0.0
2	0		900	T201962-6544	P	CHAN, CS, 1/4X2.	1	EA	I	M	0	0.0
3	0		010	WC[R]763SHR16	R	SHEAR 16'	.01	HR	I	M	0	0.0
3	0		020	WC[R]763PRBRK	R	FORM, PRESS BRA	.02	HR	I	M	0	0.0
3	0		900	MZ1301010034	N	PLATE, 1/4X72X1	43.41	LB	I	B	0	0.0
2	0		900	T201963-6431	P	CHAN, CS, 1/4X2.	3	EA	I	M	0	0.0
3	0		010	WC[R]763SHR16	R	SHEAR 16'	.01	HR	I	M	0	0.0
3	0		020	WC[R]763PRBRK	R	FORM, PRESS BRA	.02	HR	I	M	0	0.0
3	0		900	MZ1301010034	N	PLATE, 1/4X72X1	68.12	LB	I	B	0	0.0
2	0		900	T201965-4738	P	CHAN, CS, 1/4X2.	1	EA	I	M	0	0.0
3	0		010	WC[R]763SHR16	R	SHEAR 16'	.01	HR	I	M	0	0.0
3	0		020	WC[R]763PRBRK	R	FORM, PRESS BRA	.02	HR	I	M	0	0.0
3	0		900	MZ1301010034	N	PLATE, 1/4X72X1	50.19	LB	I	B	0	0.0
2	0		900	T201966-4738	P	CHAN, CS, 1/4X2.	1	EA	I	M	0	0.0
3	0		010	WC[R]763SHR16	R	SHEAR 16'	.01	HR	I	M	0	0.0
3	0		020	WC[R]761PUNCH	R	STRIPPIT	.02	HR	I	M	0	0.0
3	0		030	WC[R]763PRBRK	R	FORM, PRESS BRA	.03	HR	I	M	0	0.0
3	0		900	MZ1301010034	N	PLATE, 1/4X72X1	50.19	LB	I	B	0	0.0
2	0		900	TA201967	P	FLAT, CS, 3/4X3X	2	EA	I	M	0	0.0
3	0		010	WC[R]763BDSAW	R	SAW, BAND SAW	.01	HR	I	M	0	0.0
3	0		020	WC[R]771VIKIN	R	SHOTBLAST, VIKI	.01	HR	I	M	0	0.0
3	0		900	MZ1307010089	N	FLAT, 3/4X3X20'	10.9	LB	I	B	0	0.0
2	0		900	TA201968	P	2158, STIFPNR W	2	EA	I	M	0	0.0
3	0		010	WC[R]763BDSAW	R	SAW, BAND SAW	.01	HR	I	M	0	0.0
3	0		020	WC[R]763ACRO	R	MACHINE, ACROLO	.01	HR	I	M	0	0.0

*** continued on next page ***

15:44:14
 FUNCTION: MBIL

MULTI-LEVEL BILL INQUIRY

PAGE: 2
 07/21/1999

PARENT: 2158002065-A DESC: 2158, 20K, 5X7, 4KD
 RV: UM:EA RUN LT: 1 FIXED LT: 3
 PLNR: 3KB PLN POL: N DRWG: TC202034

LEVEL	PT	USE	SEQN	COMPONENT	C PARTIAL T DESCRIPTION	QTY	UM	Q	M	LT	SCR
1...5...10								T	B	OFF	PCT
3	0		030	WC[R] 771VIKIN	R SHOTBLAST, VIKI	.01	HR	I	M	0	0.0
3	0		900	MZ1307010089	N FLAT, 3/4X3X20'	10.9	LB	I	B	0	0.0
2	0		900	TA201969	P 2158, LC-MTG-PL	4	EA	I	M	0	0.0
3	0		010	WC[R] 763BDSA	R SAW, BAND SAW	.017	HR	I	M	0	0.0
3	0		020	WC[R] 763ACRO	R MACHINE, ACROLO	.01	HR	I	M	0	0.0
3	0		900	MZ1307020040	N FLAT, 1X4-1/2X1	11.58	LB	I	B	0	0.0
2	0		900	TC201501-105	P 2158, PLAT, DK-P	1	EA	I	M	0	0.0
3	0		010	WC[R] 764PSMAP	R PLASMA, PLASMA	.48	HR	I	M	0	0.0
3	0		020	WC[R] 764PSMAO	R PLASMA, OXYGEN-	.05	HR	I	M	0	0.0
3	0		030	WC[R] 763DRLPR	R MACHINE, DRILL	.02	HR	I	M	0	0.0
3	0		900	MZ1302010028	N TRDPL, 5/16X61X	517	LB	I	B	0	0.0
2	0		900	TN202444	P 2158, MTG-TAB, A	2	EA	I	M	0	0.0
3	0		010	WC[R] 763IRONW	R FABRICATE, IRON	.01	HR	I	M	0	0.0
3	0		020	WC[R] 763DRLPR	R MACHINE, DRILL	.02	HR	I	M	0	0.0
3	0		900	MZ1307010001	N FLAT, 1/4X1X20'	.23	LB	I	B	0	0.0
2	0		900	T202275-6544	P CHAN, CS, .25X2.	1	EA	I	M	0	0.0
3	0		010	WC[R] 763SHR16	R SHEAR 16'	.01	HR	I	M	0	0.0
3	0		020	WC[R] 763IRONW	R FABRICATE, IRON	.02	HR	I	M	0	0.0
3	0		030	WC[R] 763PRBRK	R FORM, PRESS BRA	.02	HR	I	M	0	0.0
3	0		900	MZ1301010034	N PLATE, 1/4X72X1	43.41	LB	I	B	0	0.0
1	0		900	TC202034-1	P 2158, ASSY-KOP,	1	EA	I	M	0	0.0
2	0		900	510624370	N CABLE, 6-COND, 2	25	FT	I	B	0	0.0
2	0		900	MN31004	N DATA-LABEL, MTM	1	EA	I	B	0	0.0
2	0		900	MZ0901010035	N SCR, 3/8-16X3/4	2	EA	I	B	0	0.0
2	0		900	MZ0901010298	N SCR, 1/2-13X1.5	8	EA	I	B	0	0.0
2	0		900	MZ0901010379	N SCR, 1/4-20X0.2	4	EA	I	B	0	0.0
2	0		900	MZ0909000050	N O-RING, AS-568A	8	EA	I	B	0	0.0
2	0		900	TB100395	N J-BOX, ASSY, ANA	1	EA	I	M	0	0.0
3	0		010	WC[R] 761ASMLY	R ASSEMBLE, JBOX/	.1	HR	I	M	0	0.0
3	0		900	13640300A	N PCB, ASSY, ANALO	1	EA	I	B	0	0.0
3	0		900	MZ0901010091	N SCR, 10-32X1/4,	4	EA	I	B	0	0.0
3	0		900	MZ0901010166	N SCR, 10-32X0.50	4	EA	I	B	0	0.0
3	0		900	TA800218	N DESICCANT-PACK	1	EA	I	B	0	0.0
3	0		900	TN100429	N CORD-GRIP, 3/8,	1	EA	I	B	0	0.0
3	0		900	TN100430	N CORD-GRIP, 3/8,	5	EA	I	B	0	0.0
3	0		900	TN100432	N NUT, LOCK, 3/8-1	5	EA	I	B	0	0.0
3	0		900	TB100408-5	P J-BOX, WLDMT, 1.	1	EA	I	M	0	0.0
4	0		010	WC[R] 761HSTUD	R NELSON	.02	HR	I	M	0	0.0
4	0		020	WC[R] 761SPWLD	R SPOT WELD	.033	HR	I	M	0	0.0
4	0		900	TA000009	N J-BOX, ENCLR, CL	4	EA	I	B	0	0.0
4	0		900	TB100413-5	P J-BOX, ENCL, 1.5	1	EA	I	M	0	0.0
5	0		010	WC[R] 761PUNCH	R STRIPPIT	.02	HR	I	M	0	0.0
5	0		020	WC[R] 761DBURR	R DEBURRING	.002	HR	I	M	0	0.0
5	0		030	WC[R] 761FORM2	R CINCINATI PRES	.009	HR	I	M	0	0.0
5	0		040	WC[R] 761TWELD	R TIG WELD	.031	HR	I	M	0	0.0
5	0		050	WC[R] 761POLSH	R POLISH	.019	HR	I	M	0	0.0
5	0		900	MZ1304020031	N SHEET, 18GAX48X	1.6128	LB	I	B	0	0.0
4	0		900	TB100416	P J-BOX, MTG-BKT,	2	EA	I	M	0	0.0
5	0		010	WC[R] 761PUNCH	R STRIPPIT	.005	HR	I	M	0	0.0
5	0		020	WC[R] 761DBURR	R DEBURRING	.0005	HR	I	M	0	0.0
5	0		900	MZ1304020009	N SHEET, 18GAX48X	.169	LB	I	B	0	0.0
4	0		900	TN200671	N STD-OFF, 10-32X	4	EA	I	B	0	0.0

*** continued on next page ***

15:44:14
FUNCTION: MBIL

MULTI-LEVEL BILL INQUIRY

PAGE: 3
07/21/1999

PARENT: 2158002065-A
RV: UM:EA
PLNR: 3KB

DESC: 2158, ●, 20K, 5X7, 4KD
RUN LT: 1 FIXED LT: 3
PLN POL: N DRWG: TC202034

LEVEL	PT	USE	SEQN	COMPONENT	C PARTIAL T DESCRIPTION	QTY	UM	Q	M	LT	SCR
								T	B	OFF	PCT
3	0		900	TB100423	P J-BOX, COVER, 5X	1	EA	I	M	0	0.0
4	0		010	WC[R] 761PUNCH	R STRIPPIT	.017	HR	I	M	0	0.0
4	0		020	WC[R] 761DBURR	R DEBURRING	.002	HR	I	M	0	0.0
4	0		030	WC[R] 761FORM2	R CINCINATI PRES	.007	HR	I	M	0	0.0
4	0		040	WC[R] 761TWELD	R TIG WELD	.016	HR	I	M	0	0.0
4	0		050	WC[R] 761POLSH	R POLISH	.01	HR	I	M	0	0.0
4	0		900	MZ1304020009	N SHEET, 18GAX48X	1.195	LB	I	B	0	0.0
3	0		900	TB100426	N J-BOX, GASKET, 5	1	EA	I	B	0	0.0
3	0		900	MZ0602000142	X ADHESIVE, BLACK	0	EA	I	B	0	0.0
2	0		900	TN201975	N ROCKER-PIN, .84	4	EA	I	B	0	0.0
2	0		900	TN800587	N LABEL, MT, VERTE	2	EA	I	B	0	0.0
2	0		900	TN800654	N SCR, 3/4-10X2-1	8	EA	I	B	0	0.0
1	0		900	A14691400A	N MANUAL, 2158/21	1	EA	I	B	0	0.0
1	0		900	TA800634	N CARDBD, PS-SKID	2	EA	I	B	0	0.0
1	0		900	TB800629-7	N SKID, WOOD, PS, 6	1	EA	I	B	0	0.0

*** END OF REPORT ***